

028c

INTEGRATED SLIDING DOOR electrical

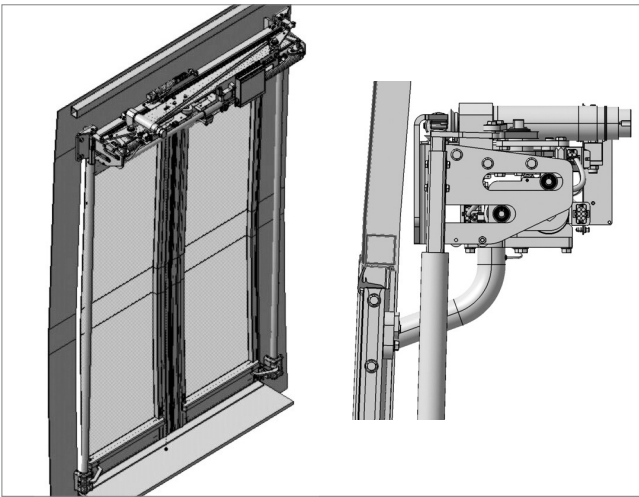
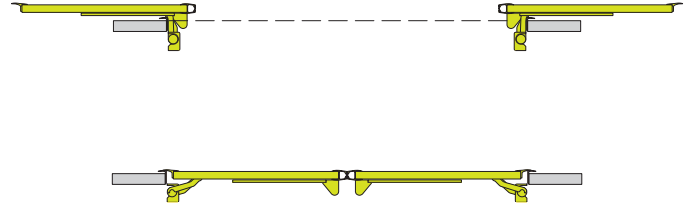

DESCRIPTION

- Fast sliding door with arm-subjection.
- Version for 2 leaves doors.
- Electric drive version 12 or 24.
- Pneumatic emergency as standard.
- Sensitization by electronic control and power sensitive rubber.
- Emergency system buttons.
- Cancellation emergency vehicle speed > 3 km / h.

TECHNICAL DATA

- Minimum pressure 6 bar.
- Temperature -30C + 70C work
- Nominal voltage 12 / 24v ± 25%
- Displacement to the outside: 85mm.
- Portal Width: 1350mm of.
- Net opening: 1200 mm.
- Vehicles destined for Class I, II, A.
- Complies UN regulations R107.

ADVANTAGES

- Easy to install and regulate.
- Fast sliding door with fastening arms.
- Simple mechanism that is integrated configuration ceiling
- Electronics is adjustable to the requirements of customers. Masats be parameterized electronic / programmable.
- It does not require door lock.
- Height and curvature adapted to the vehicle.
- Fully glazed leaf, single crystal (optional double).