

Chassis - safe and comfortable

for trucks, buses, agricultural machinery, construction machinery
and special vehicles



Content

Chassis components

- 04 Expertise in Chassis Technology
- 06 Independent suspension components

Chassis dampers

- 08 Vibration damping in the vehicle
- 09 LDM – Air Spring Damper module
- 10 PCV - Premium Comfort Valve
- 12 N-Damper for trucks and buses
- 14 CDC® - Continuous-Damping-Control
- 16 CDC + CDC^{xl}

Chassis systems

- 18 Rear axle suspension
- 20 AIRTRAC und AIRTRAC X
- 22 Axle systems for trucks

Cabin suspension systems

- 24 Driver´s cabin suspension
- 26 Vibration damping for the driver´s cab
- 30 CDC® – for the cabin

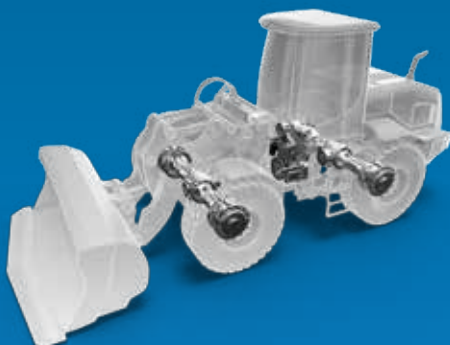
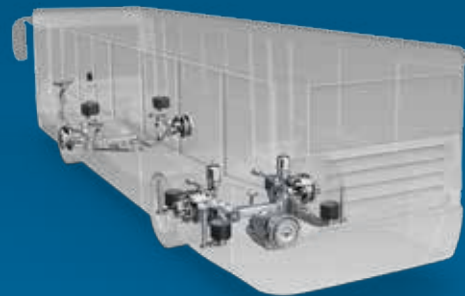



RELIABLE AND INNOVATIVE

For more than 60 years, ZF has been supplying innovative chassis products to manufacturers of trucks, buses, agricultural machinery, construction machinery, special vehicles. Within the ZF Group, we are the specialists for CV chassis technology.

As a partner for added value in the commercial vehicle industry, we work with state-of-the-art technology and – as a global leader – offer our customers the best solutions in the product lines axle and wheel suspension, steering components, drivers cabin suspension, dampers and damping systems.

Expertise in Chassis Technology

Our design expertise guarantees fast implementation of growing safety requirements and increasing comfort standards.

This is how we develop optimum chassis technology with outstanding safety standards – the basis for problem-free transport of goods weighing several tons. Short development times from initial talks to components ready for production and strict compliance with technical specifications guarantee top customer satisfaction. That's a promise.

Lightweight chassis design

We are committed to the permanent improvement of our products and processes. ZF optimizes lightweight construction with new materials and engineering processes, with innovative product design and extensive process experience. The business unit provides essential impetus for continuous weight reduction in commercial vehicle construction. Our product innovations increase the payload, reduce fuel consumption, and enhance the comfort of commercial vehicles. The result of this optimization is the use of lightweight materials such as aluminum torque rods or design optimizations through the use of casting technology for torque rods and v-links. Another way of reducing weight is function integration, achieved for instance with our 4-point links. These optimizations are aimed at reducing

costs and improving driving dynamics. The focus here is on the chassis as a safety component.

4-point link:

Integration of functions and weight reduction

The 4-point link integrates the functions previously performed separately by the v-link and the stabilizer bar, and fulfills all of the familiar role stabilization requirements. Axle control is ensured even in extreme driving conditions, ground clearance is improved considerably in comparison to previously existing systems, and the weight of the system is reduced by an average of 20 kilograms.

In addition, the new link improves driving safety over the entire performance range of the chassis. For commercial vehicle manufacturers the new chassis module provides further benefits, since it represents an advance in the standardization of axle variants. Incorporation of the 4-point link into the chassis reduces the number of components and hence the associated tool and development costs. The functional integration also decreases assembly costs.



4-point link casted version



4-point link study using glasfiber-reinforced plastic composite



Advantages

- Integration of functions
- Reduced weight
- Simplified assembly requirements and high level of modular compatibility
- Increased ground clearance due to elimination of the stabilizer
- Reduction of parts



Advantages

- Lightweight construction
- As 4-point link cast version



V-link made of aluminium



Chassis stabilizer



V-link with transverse lug



Torque rod, adjustable on both sides



Torque rod



Advantages

- Robust
- Maintenance-free
- Reduced weight
- Higher payload

Independent suspension components

More safety and comfort in commercial vehicles.

The demand for even better passenger comfort in coaches requires new axle suspension concepts. That is why ZF started developing independent suspension systems according to the principle of double-wishbone axles at an early stage. This successful concept is set to be applied increasingly in trucks as well as special vehicles because the benefits in terms of safety and comfort apply here as well.

ZF – your development partner.

Cooperation within the ZF Group is a given, but ZF is also a development

partner for many systems suppliers worldwide. We develop and supply ready-to-install modules for the axle systems of our customers.

You get ahead with ZF.

We cooperate intensively with our customers – from development to volume production. We take on the development work right through to the design of efficient logistics concepts to give our customers the space to focus on their business.



Corner module
for agriculture vehicles



Corner module
for special vehicles



Control arm
casted version



Control arm



Control arm with suspension joint
and molecular joint for special vehicles



Suspension joint



Advantages

- Noise-optimized joints
- Reduced weight
- Maintenance-free
- Robust

Vibration damping in the vehicle

The primary suspension absorbs excitations originating from the road. The suspension enables the wheel to follow the unevenness of the road. However, the stored energy is released again by the suspension system when the wheel is rebounding. The chassis needs shock absorbers to dampen vibrations caused by this as quickly as possible.

Sprung and unsprung masses vibrate in different frequency ranges. Shock absorbers aligned with vehicle suspension basically prevent the body from rocking and vibrating. They ensure permanent road grip of the wheels and thus good lateral guidance and braking effects. Damping plays a decisive role in driving safety and ride comfort.

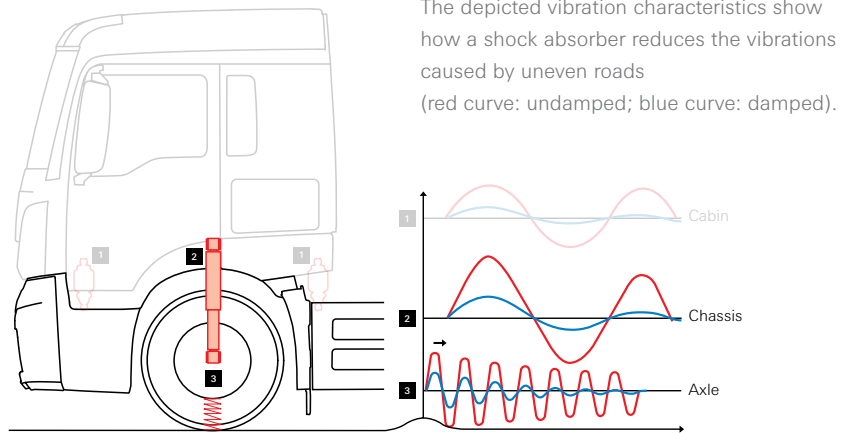

Damper Sizes

Light commercial vehicles

Light trucks

Medium and heavy-duty trucks and buses

Special Applications

Damper sizes	S27 ⁽¹⁾	S30 ⁽¹⁾	N30	N36	N45	N50	T70 ⁽²⁾
Rebound [N]	3.500	4.500	6.000	11.000	16.000	20.000	30.000
Compression [N]	1.500	1.500	1.800	3.500	6.000	10.000	20.000

Maximum permissible nominal damping power with a piston speed of 0.52 m/s
 (1) Standard shock absorbers for light commercial vehicles and light trucks
 (2) Standard shock absorbers for special applications

Ideal damper size

The ideal shock absorber size depends on the forces of inertia present and on the suspension system. This results in the required damping forces.

In addition, the length and diameter define the heat dissipating surface area. The larger the shock absorber, the larger is the surface area and the higher is the thermal load capability.

Product range damper



LDM – Air spring module

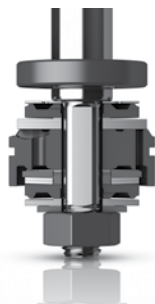

PCV® – Premium Comfort Valve



N-damper for trucks



N-damper for buses



CDC® – Continuous Damping Control

LDM – Air Spring Damper module

The LDM air spring damper module is an alternative to the established concept of installing dampers and air springs next to one another in the suspension. It is a compact unit consisting of both an air spring and a damper.

By reducing the number of individual components and saving installation

space, the LDM significantly contributes to the new front axle requirements. This design is in a way similar to air spring damper modules for cabin suspension. They are ideally suited for the innovative axle designs of the future.

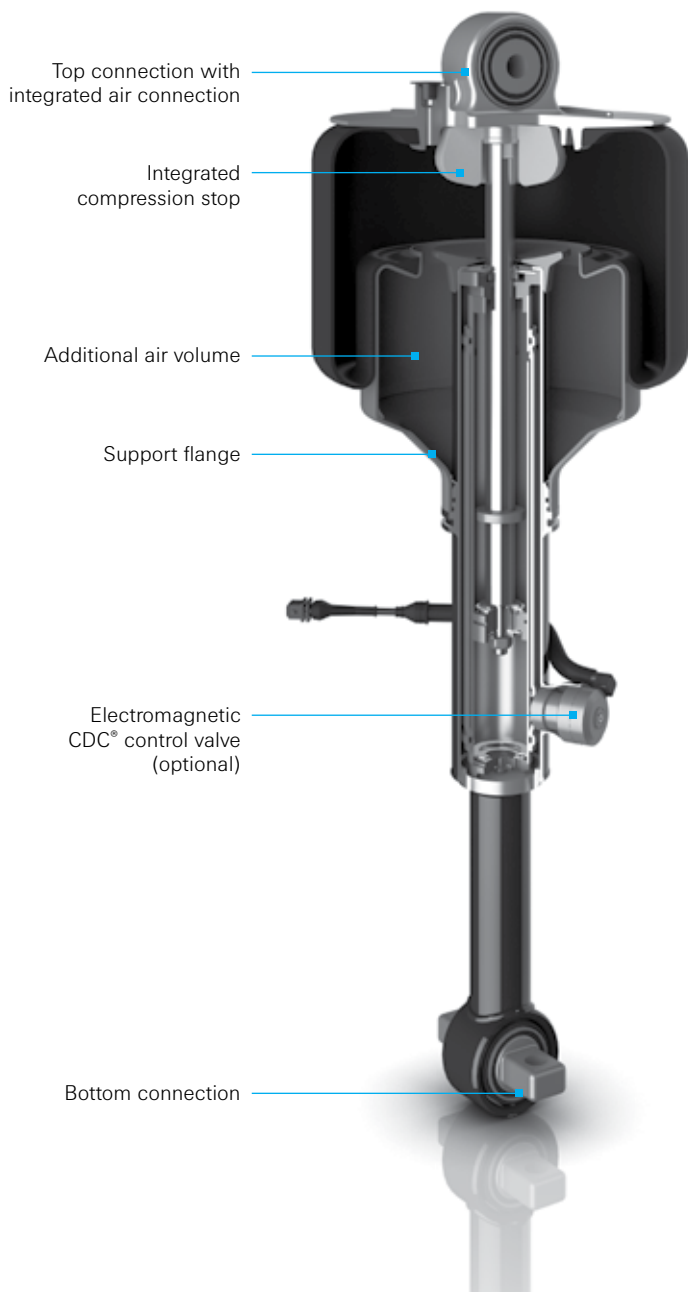

Advantages

- Improved anti-roll stability – especially important if body has high center of gravity
- With the respective axle kinematics, larger spring travels result, e.g. when swap trailers and semitrailers are attached
- Reduced installation space
- The combination of spring and shock absorber enables a wide spring track
- Sizing of the outside dimensions of the bellows and rolling piston make high axle loads possible
- LDM can be combined with the continuous damping control system, CDC®

Application

Air spring damper modules are used in trucks and buses for independent wheel suspensions and for conventional suspensions on the front axle.

Premium Comfort Valve – PCV®

When stability simply feels good.

A high degree of comfort is a core requirement in coaches. That's where innovative damper technology comes in, which is provided by ZF. PCV combines comfort and stability. It also significantly reduces hydraulic noise.

With the introduction of alternative drives, the arrangement of units and components changes; for example, batteries are partially located in the roof. Greater damping is required to take account of the higher center of gravity.

PCV is the ideal system to ensure that comfort is not compromised: by lowering the comfort-relevant damping, it offers the possibility of not having to accept reduced comfort but at the same time ensures that very good vehicle stability is achieved.

This means that the vehicle is comfortable, safe and stable at the same time.

The characteristics of PCV also reduce the transmission of disturbing noises into the passenger compartment.

Individual adjustment to a wide range of buses

The core of PCV technology is a new piston valve concept, in which numerous parameters are available.

This makes it possible to generate characteristic curves that correspond even more precisely to the customer's wishes and the requirements for the vehicle. This is another new standard that ZF sets for buses.

Safety due to regulated damping force

A great increase in damping force in the range of low damper speeds reduces rolling and pitching motions to a minimum.

At mid-range speeds, the changed oil feed system ensures a slow increase in damping force, which improves comfort.

The damping force increases again at high deflection speeds in order to keep the vehicle stable without pitching and oscillation of the vehicle body.

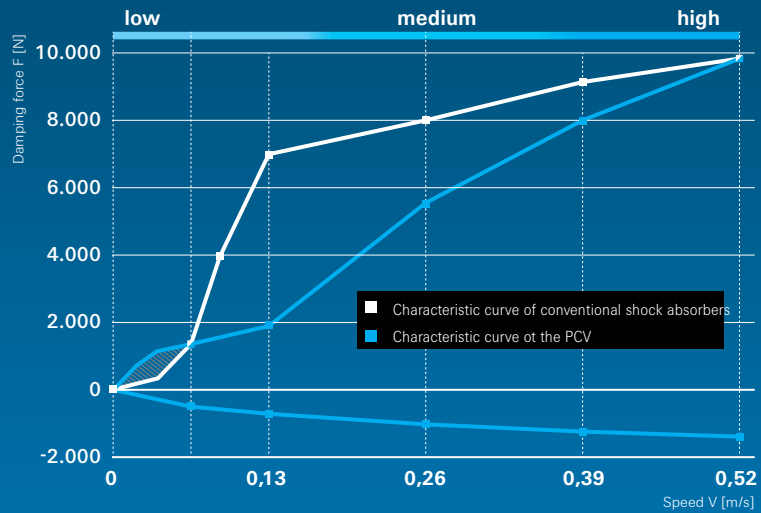
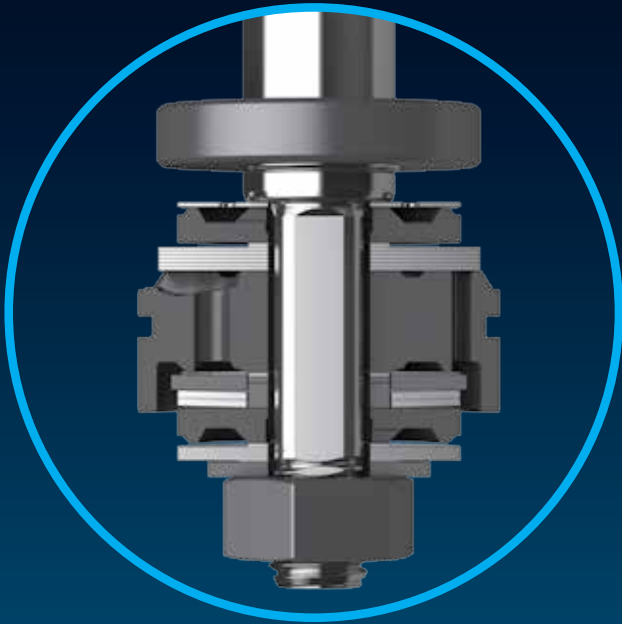

Advantages

- Greater comfort without loss of stability
- Strong damping of axle movement at low deflection speed possible
- Harmonious trend of the damping characteristic curve
- Minimization of the noise situation in the vehicle
- No external control systems

N-Damper for trucks

The N-damper was specially developed for modern air and parabolic springs. It has proven itself in longdistance trucks and under extreme conditions in heavy terrain.

N-dampers by ZF operate on a twin-tube principle. When the suspension is compressed, the piston rod moves in (compression stage). This pushes a quantity of oil corresponding to the volume of the piston rod through the damper base valve into the outer tube. At the same time, the annular volume of oil is pushed from the lower into the upper working chamber through the piston valve.

When the axle load is released, the piston rod extends (rebound). The annular volume flows back through the piston valve. A quantity of oil corresponding to the volume of the piston rod is sucked from the oil reservoir in the outer tube through the base valve.

Application

The N-damper is used in all truck and semitrailer applications.

Damping force and characteristic curves

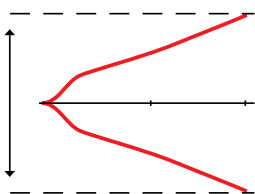

Progressive-linear characteristic curve development for leaf spring vehicles.

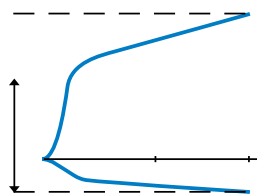

Degressive course of the characteristic curve: ideal for parabolic spring and pneumatic spring vehicles thanks to patented piston system.

In general, the damping force of the shock absorber depends on the piston speed: The damping force increases with increasing piston speed. The valves define to which extent this happens. The special design, arrangement, and combination of the valves make it possible to achieve all desired damping characteristics (characteristic curves) that are required and ideal for the respective use.

The damping force characteristic is individually adjusted for each vehicle series. The characteristic is defined in close cooperation with the vehicle manufacturer. Thus, full driving stability is guaranteed even when the vehicle is fully loaded.



Advantages

- Long service life
- Great tire comfort
- Low friction
- Multi-stage piston and base valves
- Perfect for modern air suspension concepts

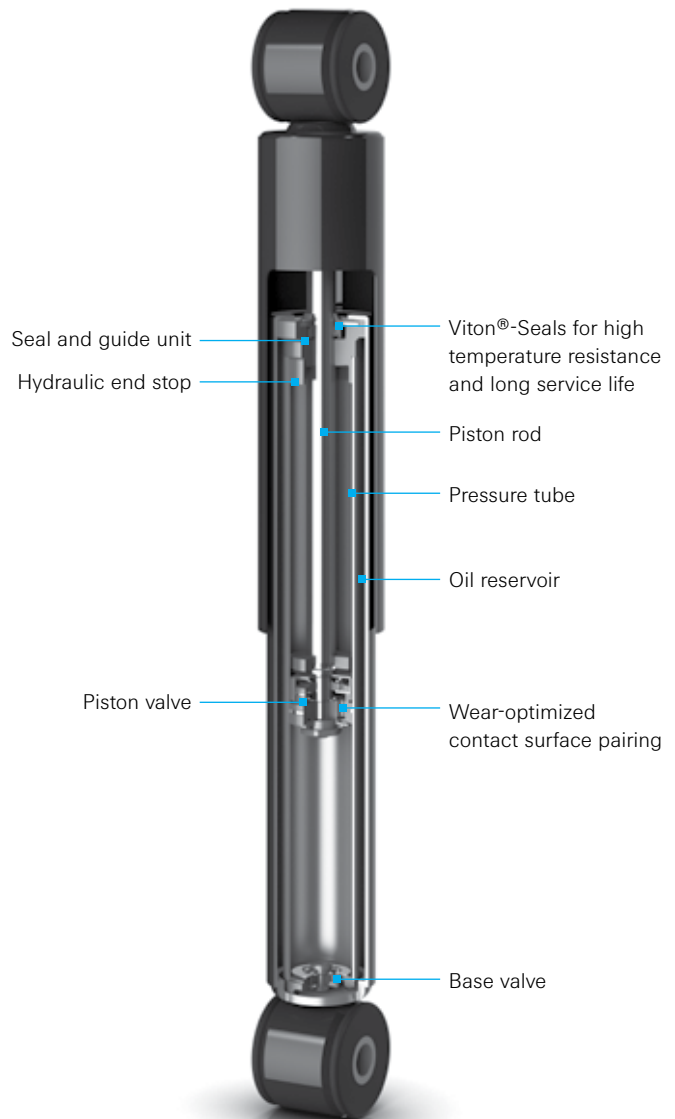

N-Damper for buses

ZF has optimized the established N-damper generation especially for bus applications. New piston and base valve concepts take into account the special resonance properties of buses, significantly minimizing the transmission of noise. Combined with newly developed comfort joints, passengers enjoy ideal drivability and maximum noise isolation. Adjusting the correct ride height is facilitated by the well-proven knurling of ZF dampers. The new heavy-duty lower stud offers high load-carrying capacity and long service life, especially on difficult roads.

Thanks to a high-quality zinc-nickel coating, the metallic surfaces have an exceptionally long service life. That way, they are protected against corrosion. In addition, they ensure the well-known long service life of ZF's N-dampers, even under extreme environmental conditions.



Advantages

- Minimized noise transmission
- Optimized piston and bottom valves
- Mounts optimized for comfort
- Increased service life
- Reinforced bottom stem mounts
- Zinc-nickel coated joint parts
- Knurling to ensure correct ride height
- Further increase in comfort through VARIO technology

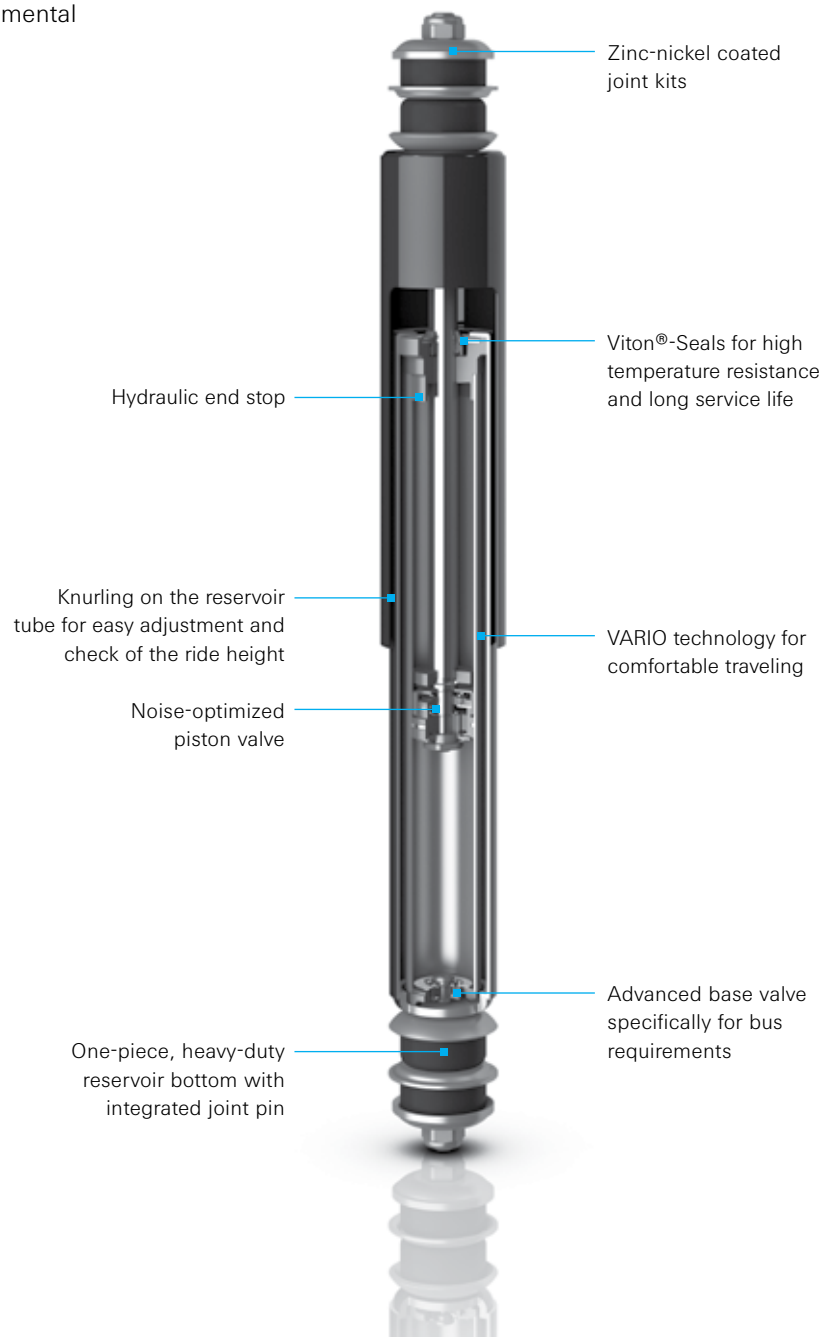

CDC®

CDC® – Continuous Damping Control Perfect Damping Anytime

CDC® is the damping control system for buses and commercial vehicles that combines uncompromising comfort and driving safety – from a single source, from ZF.

The CDC® electronically controlled damping system permanently monitors all relevant influences on the driving situation, such as load condition, driver activities, vehicle movements, etc. The CDC® optimally sets the damping force within a few milliseconds. The vehicle should get as much damping as it needs in the respective situation, but as little as possible as a matter of principle. In this way comfort is maximized and stability is achieved if necessary. It is no longer necessary to compromise between safety and comfort with the shock absorber setting.

With CDC®, the vehicle remains stable and safe to control in all situations. Damage to load, packaging, and vehicle are kept to a minimum. Driver and passengers experience significantly less bodily stress. This applies in particular to special applications in motorhomes or ambulances. The feeling of comfort is higher and the driver can concentrate better on his task: driving the vehicle.

ZF develops CDC® as a system for commercial vehicles and delivers significant advantages in comparison to previous solutions. This is primarily thanks to the use of the skyhook control principle. Both ride comfort and vehicle stability are noticeably improved in all laden states. The ZF system can be used both as a complete system and as the CDC^{1XL} single-axle solution.

CDC^{1XL} is a particularly efficient variant of the CDC®. The shock absorbers on only one vehicle axle are controlled and damped. Usually that is the rear axle, since the largest axle load differences occur there due to vehicle loading. The performance of the new CDC® control concept is already clearly visible with this limited application.

To achieve optimal vehicle handling for the overall vehicle, we continue to recommend the full CDC® system which appropriately controls all shock absorbers.

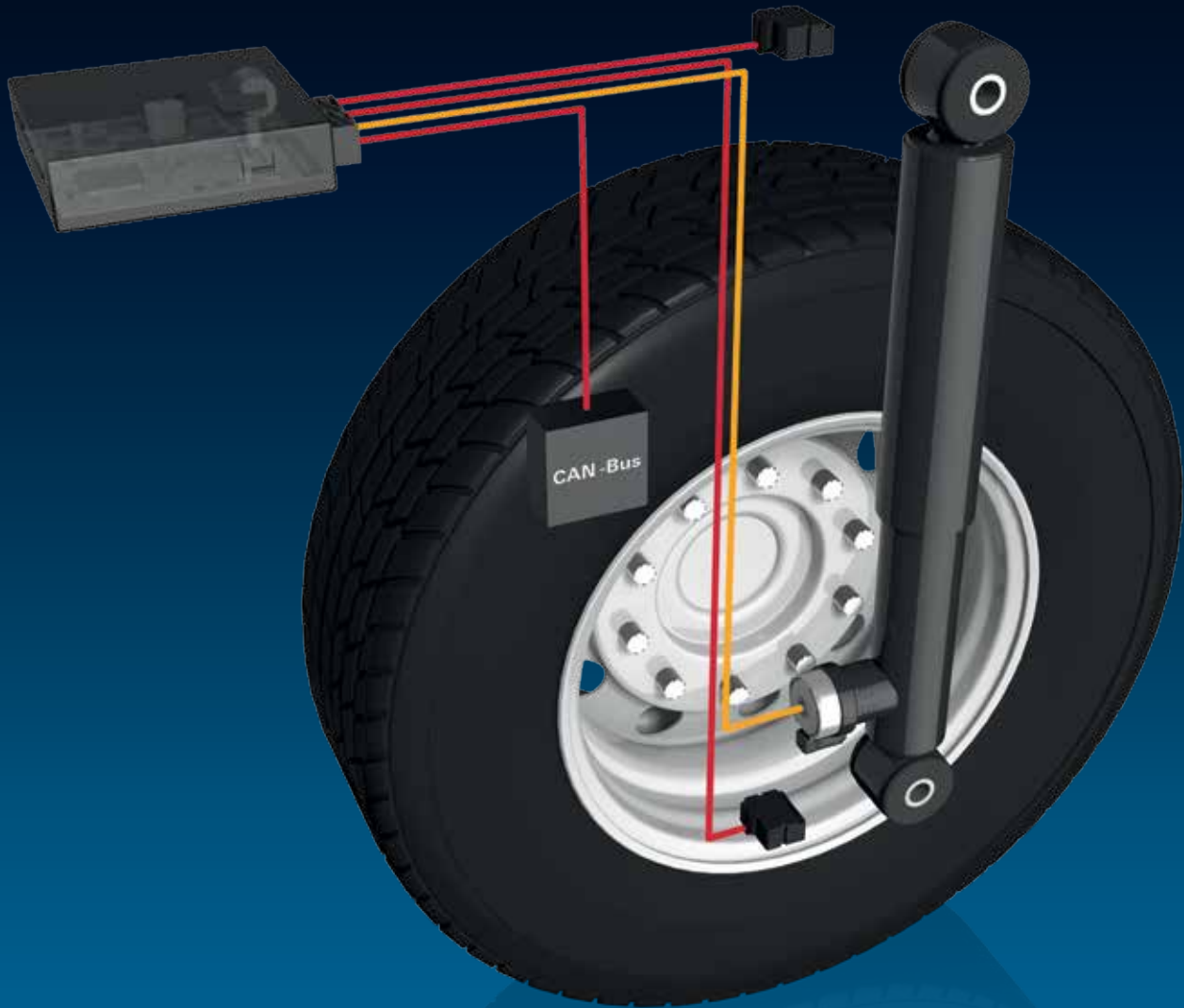

**Der CDC®-modular kit –
Solutions for a wide variety of requirements**

	Full CDC® version	CDC ^{XL}
Sensor systems	CAN data and possibly separate sensor system	Sensor cluster integrated in ECU A-CAN (if suitable)
Control unit	Independently by wheel	Independently by axle
Application	For all trucks and buses, 18 wheels can be dampened independently	Primarily rear suspension due to load differences



Advantages

- Stability even in critical driving situations
- Safe handling during dynamic driving maneuvers
- Comfort for driver and passengers
- Protection of cargo, packaging, and vehicle body
- Reduced vehicle wear
- Reduction in road damage
- Increase in cost-effectiveness

The CDC®-system

CDC® is an intelligent control system composed of system sensors, control unit, and CDC® dampers.

The sensors determine the current driving situation. CDC® uses the data of the sensor cluster integrated into the ECU as well as the information available on the CAN bus.

An important component of the CDC® damper is an electronically controlled

proportional valve. The oil flow rate is increased or decreased depending on the demand. The required valve position is permanently re-calculated and continuously adjusted.

The system can adjust the damping force in just a few milli-seconds and can do so independently for each axle and wheel. The use of the skyhook principle makes the CDC® clearly noticeable.

Controlled Damping

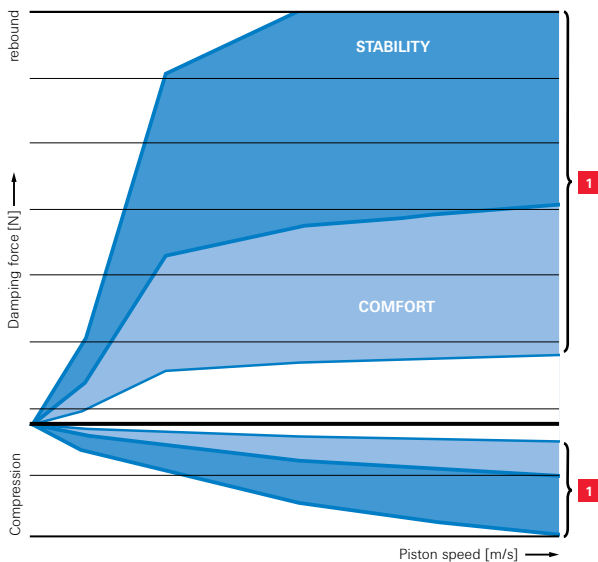

1 Damping force adjustment ranges

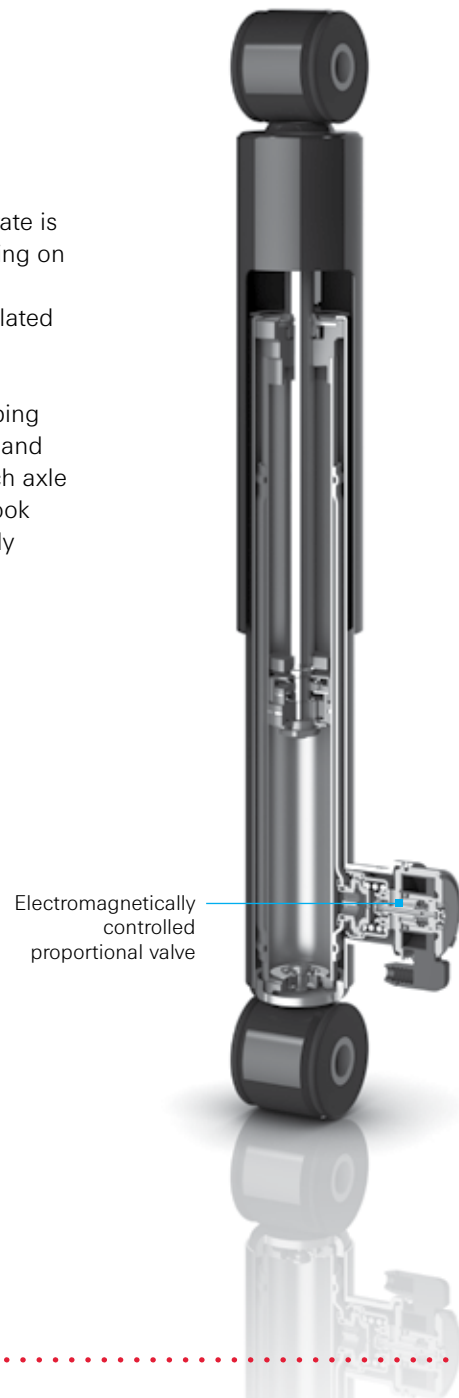

Benefits with CDC®

Safety

Vehicle remains stable in terms of driving dynamics and is easy to keep under control even in challenging situations

Greater safety and better handling in highly critical maneuvers:

1. Braking: Potentially shorter braking distances
2. Lane changes: Better control and handling due to lower roll angle
3. Steering: Smaller steering angle
4. Acceleration: Less pitching, better wheel control

Cargo protection

Less damage to cargo and packaging; cargo remains securely fixed on load floor

Vehicle wear

Vehicle components are subject to less stress; maintenance costs decrease

Ride comfort

Reduced vehicle body and seat acceleration; CDC® lowers driver fatigue; passengers have a more pleasant trip

Road protection

Reduction in damage caused by dynamic loads

Cost effectiveness

Vehicle components are subject to less wear, maintenance costs decrease, less tire wear; potentially lower insurance premiums

CDC^{1XL} – the solution for one axle

CDC^{1XL} is a cost-optimized variant of the CDC[®] damping system from ZF. Since the system is only used on the rear axle (because of the greatly varying laden states), this leads to a significant reduction in system costs with simultaneously high system Advantages.

The high performance of the CDC^{1XL} is determined by the correspondingly adapted ZF controller.



Conventional damping



Controlled damping

CDC^{1XL}-Control loop (Example)

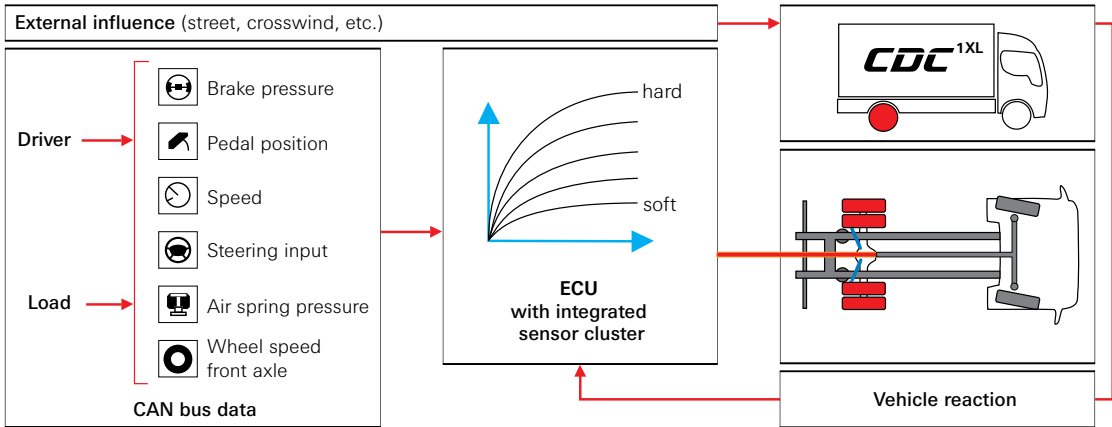

The CDC^{1XL} uses the sensor cluster integrated into the controller to determine the relevant control variables itself. Thus, it can be easily

integrated into existing vehicle concepts. In addition to the load signal, steering input via the CAN bus can be used in order to increase the roll resistance of the vehicle during cornering.

Noticeable Improvement with CDC^{1XL}

The subjective improvement is verified by objective measurements. A frequency analysis shows objective

improvements in the relevant frequencies. The data show, that CDC^{1XL} uses the damping force range to the best benefit.

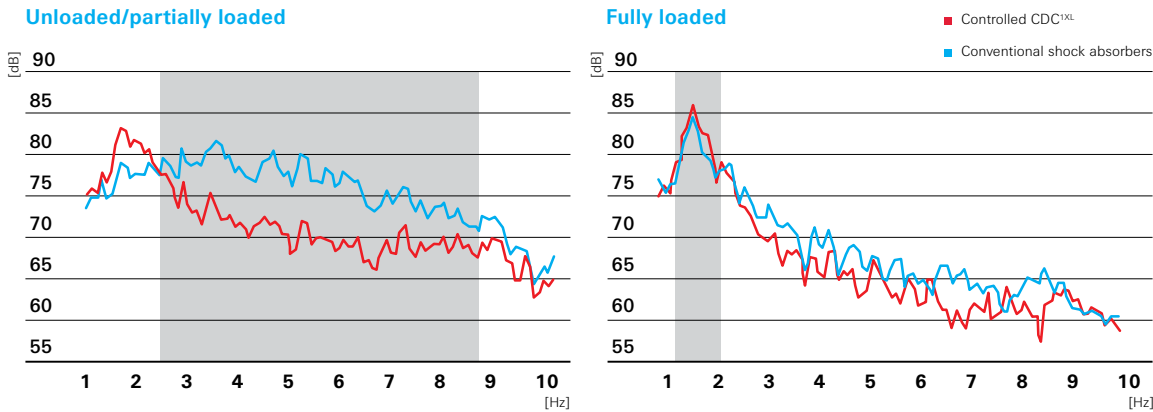

In unloaded and partially loaded vehicles, vibrations and motions are noticeably reduced – this means more comfort.

In a fully loaded vehicle, driving stability remains on the same level compared with conventional shock absorbers – at very good comfort.

Rear axle suspension

Systemized performance

Less can be more. This is also true for the truck chassis. ZF uses lightweight design for the innovative rear axle suspension system to increase efficiency. To save fuel and increase the loading capacity.

Reduced unsprung masses in the vehicle also translate into greater comfort and reduced wear on bearings. The ZF total solution described here achieves a significant weight reduction by integrating functions and the use of lighter materials, for example in the 4-point link or aluminum v-link.

ZF offers axle suspensions with various mounting systems, which can be combined as required. This includes the conventional axle suspension, axle suspension with stabilizer link or suspension with 4-point link.

The version shown is the 4-point link for guiding the non-driven leading axle with weight-optimized, hollow-cast design. In the case of the driven rear axle, a stabilizer link with new polygon joining technology is used. Together with a lightweight aluminum v-link and a spring bellows carrier, it takes over the axle guidance in longitudinal and transverse directions and the vertical axle load support.

Thanks to constructional improvements made to both axles, the

.....
20 %
weight-reduction
.....

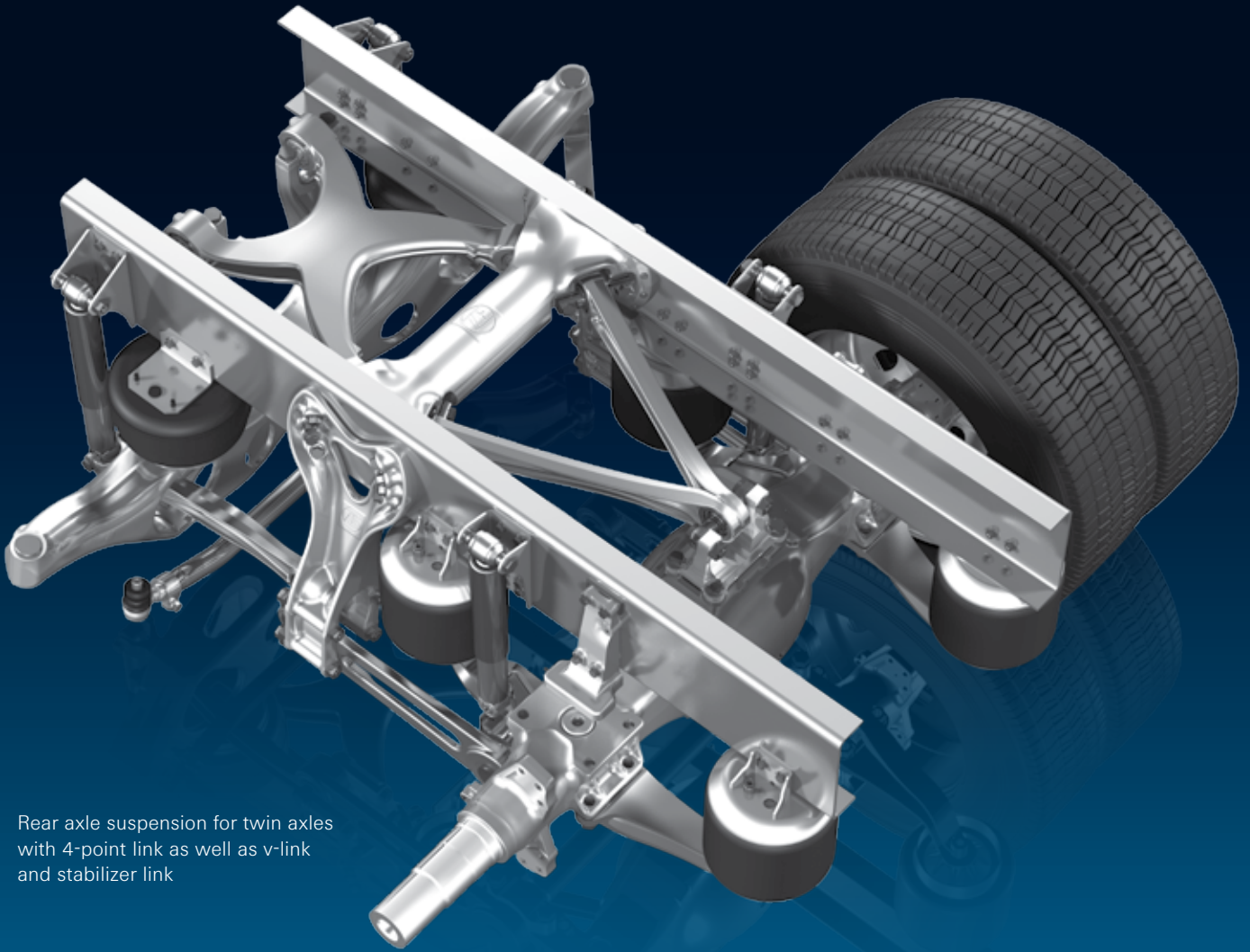

Rear axle suspension for twin axles with 4-point link as well as v-link and stabilizer link

new rear axle suspension weighs considerably less, leading to lower unsprung masses in the vehicle. This is crucial to safety and comfort. Fleet operators benefit from lower vehicle weight because the payload can be increased and the relative fuel consumption reduced, e.g. by savings made during empty journeys and partial loading. Another positive side effect of the weight reduction is protection of the streets and reduced wear on the chassis mounts.



.....
Economizing with ease

- Optimized rear axle suspension for twin axles integrates two lightweight construction solutions
 - Increased payload thanks to lower vehicle weight
 - Integration of functions
 - Reliable
 - Modular solutions
-

Airtrac

The easy adaptable solution

A systematic approach to comfortable axle suspensions:

The Airtrac suspension from ZF offers a comfortable and reliable overall solution for modern truck chassis. The characteristic advantages of an air suspension comply with the growing legal requirements regarding road surface protection and the increasing demand for payload security. The modular Airtrac includes a solution for liftable rear axles offering significant weight and cost savings.

The system and its individual components are robust, long-lasting and maintenance-free. The ZF torque rods and

V-links guarantee ideal axle guidance thanks to the elastokinematic properties of their bushings.

In addition, ZF shock absorbers are important components of a safe and comfort-optimized truck suspension system. ZF offers all this as a full service supplier.

Our customers' demands can be met by intensive cooperation from development to volume production including efficient logistics concepts. ZF's well established axle suspension Airtrac has been successfully launched in the market, having already received customer awards.



Modular

- Individually configurable for 4x2, 6x4 or 6x2 applications for low-deck or standard ride-height
- Easily adaptable
- Cost advantages due to modular design using large numbers of identical parts
- Also suitable for small volume application

Full Service

- Development and Testing
- Serial Supply
- German engineered
- Logistics
- Extended warranty available

AirtracX

The innovative lightweight solution

The requirement of the market for further weight reduction has been solved by ZF with the new axle suspension system AirtracX.

The innovative lightweight suspension AirtracX was developed by ZF as an enhancement of the proven Airtrac

system. The special weight optimized construction of the AirtracX is built around its 4-point link principle. This allows a higher payload as well as a lower fuel consumption. AirtracX offers the same special advantages of air suspension as Airtrac.



AirtracX:

- Innovative lightweight construction
- Individually configurable for 4x2, 6x4 or 6x2 applications for low-deck or standard ride-height
- Weight advantages through the 4-point link
- Fuel savings
- Higher payload
- Ideal for mid to high volume application

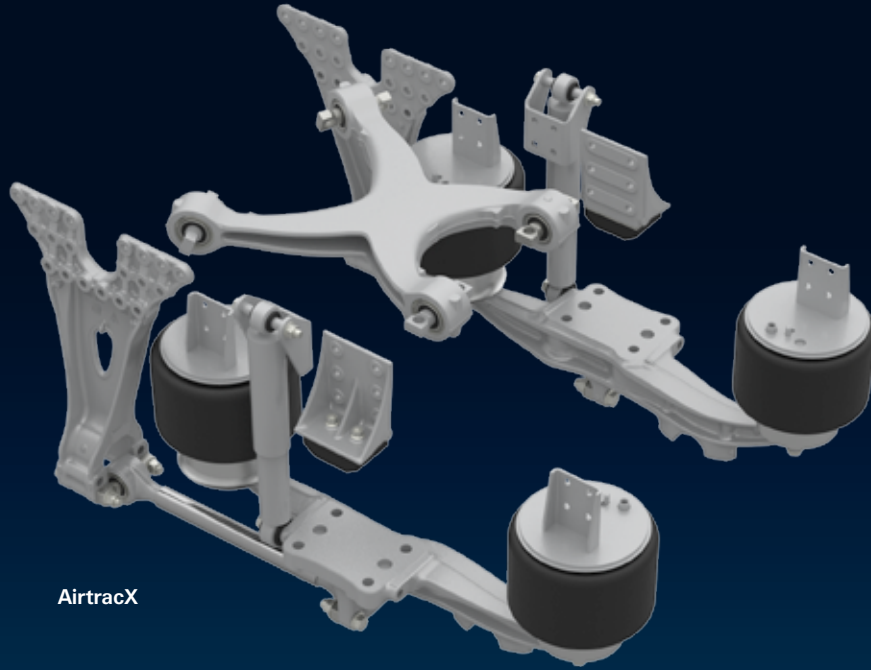

AirtracX

Airtrac

AirtracX

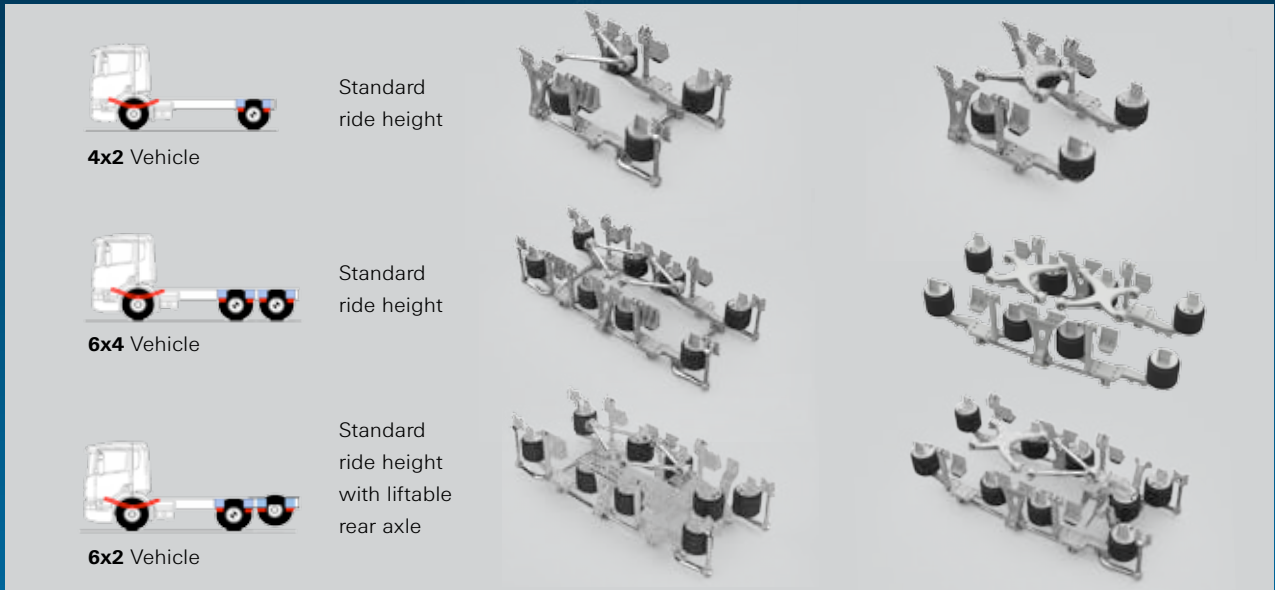

Tested Reliability



Performance by ZF

Axle system for automated trucks

Extreme driving precision and perfect body roll comfort: ZF's innovative axle steering system for heavy trucks demonstrates the potential of intelligently designed individual axle steering systems.

The solution for long-distance heavy freight transportation. The centerpiece is the combination of electrified steering and a wheel suspension based on comfort and safety, which has made it possible to redesign the basic layout of the driver's cabin. The result is an innovative front axle with steering angles of up to 50 degrees.

The redesigned axle suspension combines the highest level of comfort with the highest safety standards. The innovative kinematics incorporates an optimized anti-dive effect for outstanding suspension comfort. By incorporating elastomer bearings on the frame mounting points impacts are reduced to a minimum. The development objective, however, was not only to improve ride comfort, but also to protect road surfaces. The air-spring damper module (LDM) supports all of this by providing ideal damping and chassis suspension while requiring minimal installation space.

ZF's steering system provides a combination of electrical and hydraulic steering, bringing together their respective Advantages. The hydraulics provide the basic steering support. This is increased by the additional electrical support to the required level for the necessary steering support.

The advantages of both systems only become apparent in the combined axle steering system. The goal was to design a high-precision steering system combined with optimal ride comfort and safety. This is reflected in excellent handling with a simultaneous reduction in vehicle body movements. Both systems are, however, self-sufficient, which also makes it possible to use the system in other combinations.

Compared to the current air-spring solid axle which is guided by torque rods, the axle system shown here is 40 kilograms lighter in total – a difference

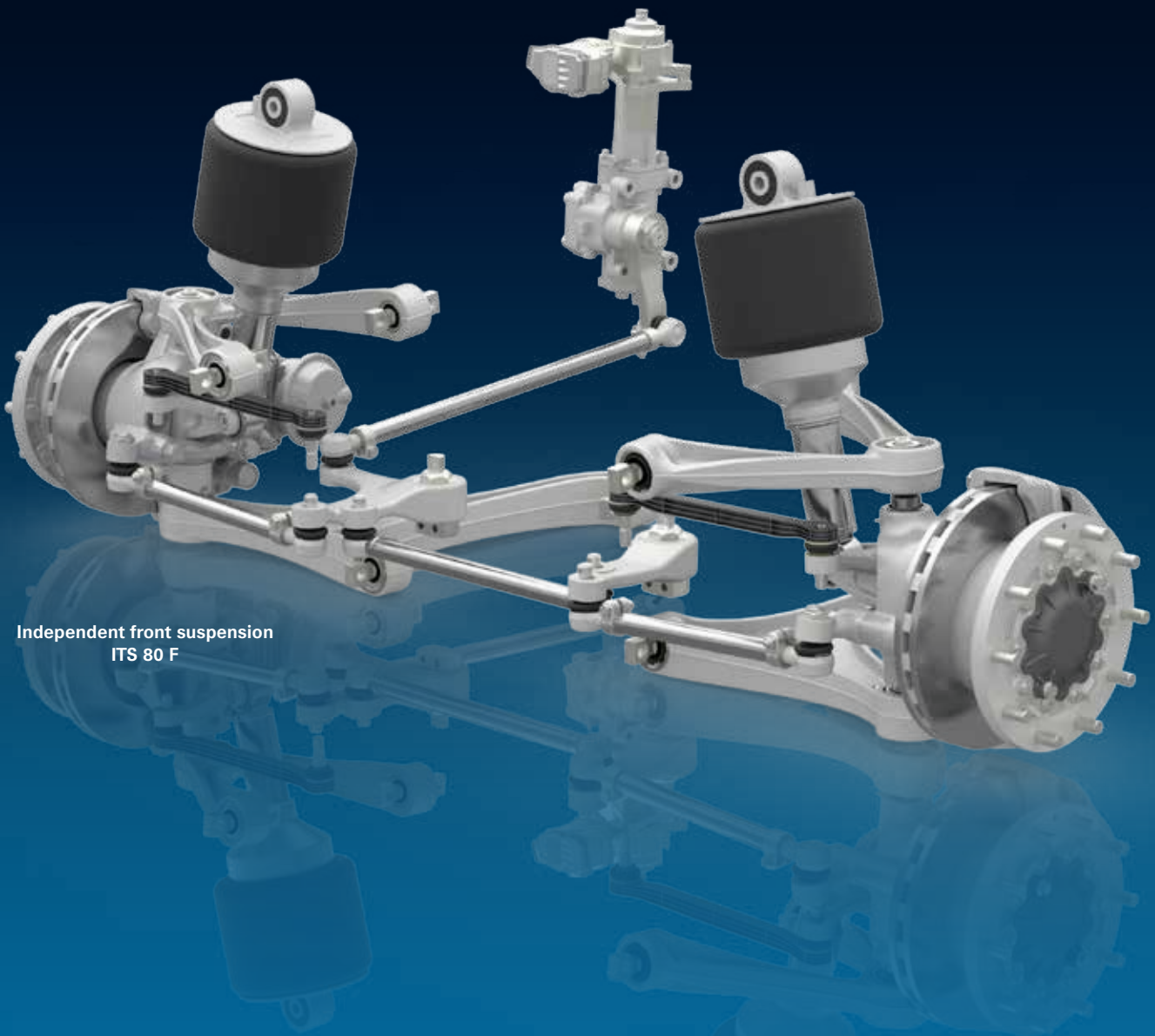

Independent front suspension
ITS 80 F

of more than ten percent compared to a conventionally produced independent suspension. The lower total weight saves fuel and keeps the emission values low.



Cost reduction with light weight

- Improved ride comfort using innovative chassis technology
- Optimal handling
- Electrified high-precision steering system
- Interface for assisted steering functions
- Steering angle up to 50 degrees
- 40 kg lighter

Comfort for the Driver's Cab

Innovative cabin suspension

ZF cabin suspensions ensure driver comfort and optimize both functions and space. Good working conditions in commercial vehicles are not a luxury but a prerequisite for getting the driver, vehicle, and goods safely to their destination.

As a system supplier, ZF develops and produces cabin suspensions for all applications in commercial vehicles – including springs, vibration dampers, and rubber-metal components. Every time, we offer you the optimal solution customized to your requirements. Drivers benefit from a more comfortable workplace with fewer jolts, pitching, or rolling motions. The various commercial vehicle fields of operation require different cabin types that in some cases differ widely in terms of dimensions, features, and weight.

Comfort and optimized use of space

ZF develops cabin suspensions for various requirements. The result? Good working conditions for drivers. Just like the commercial vehicles themselves, the cabin suspensions are designed for very different applications. The requirements range from robust off-road capabilities, e.g. for construction vehicles or tractors, to comfort-optimized designs for long-distance driving on freeways.

Customized solution for every cabin

Regardless of the type, size, and equipment of the driver's cab, ZF offers the best solution for cabin damping and suspension.

The range extends from medium and heavy trucks of all application categories through to off-road and agricultural machinery.

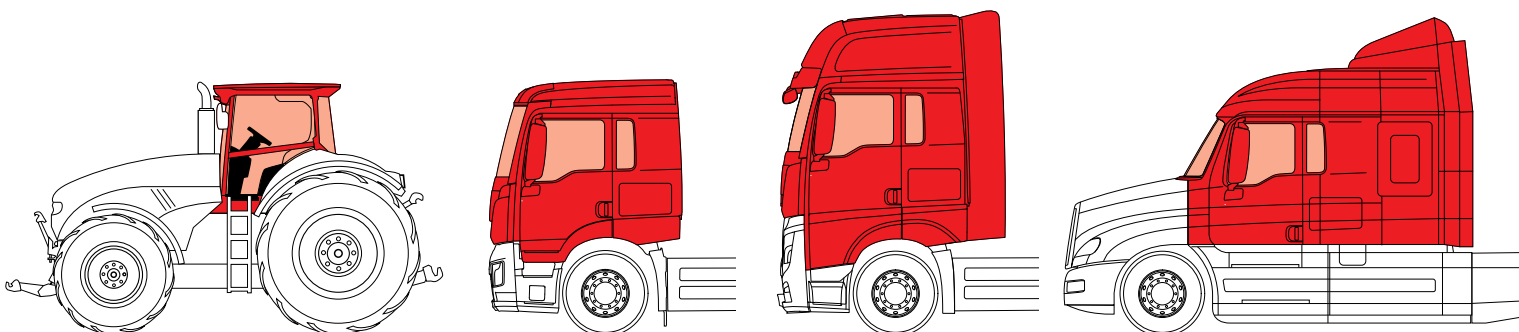

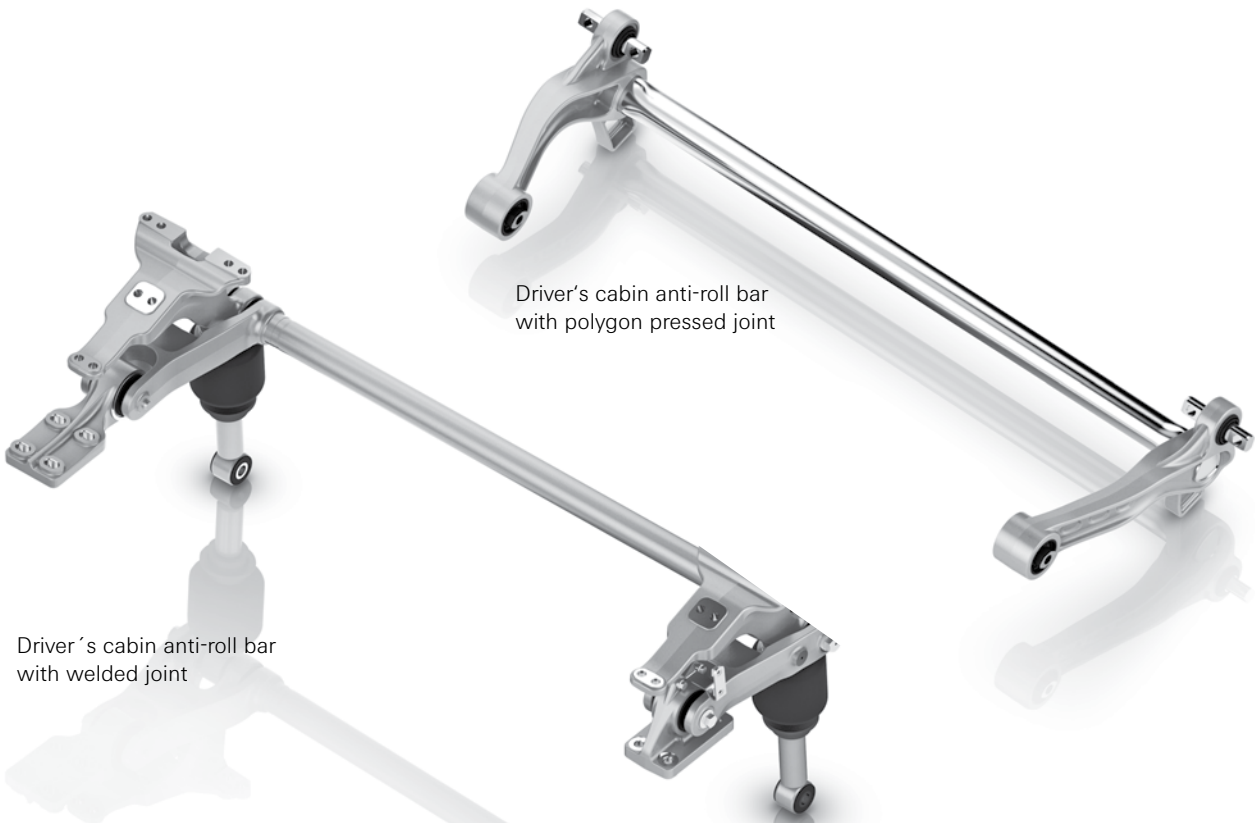

Driver's cabin anti-roll bar with polygon pressed joint

Driver's cabin anti-roll bar with welded joint

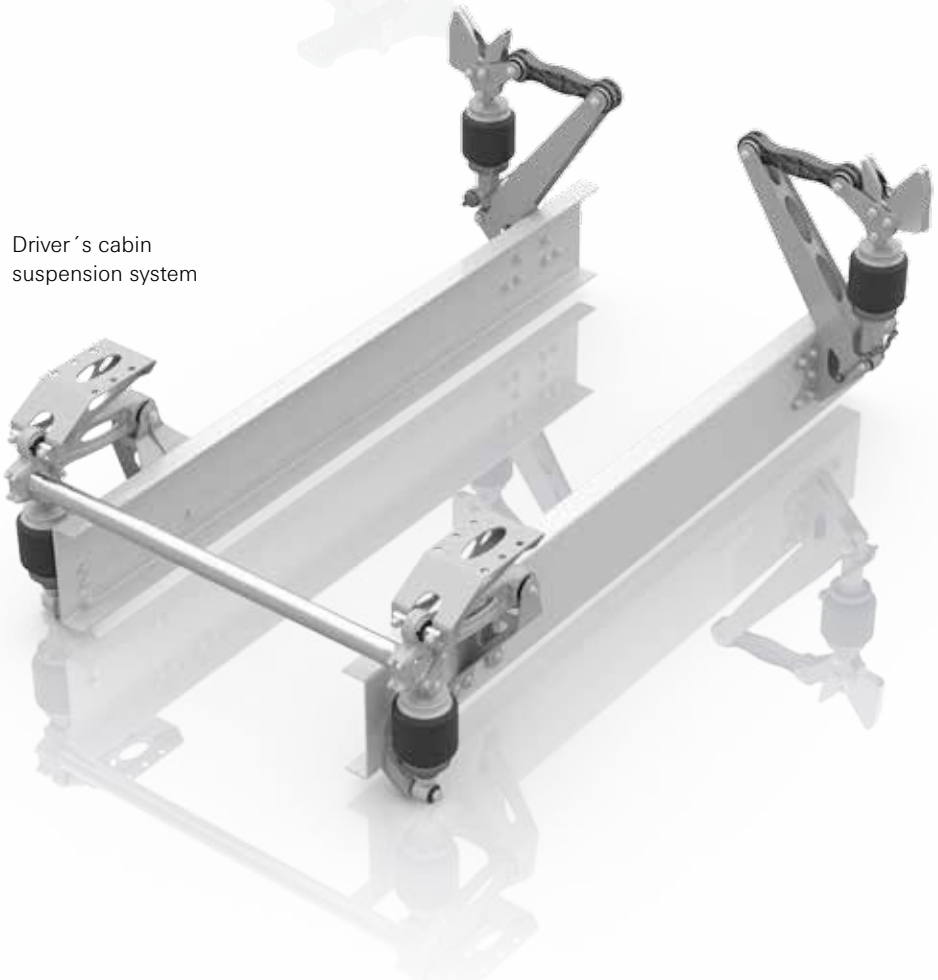

Driver's cabin suspension system

Vibration damping for the driver's cab

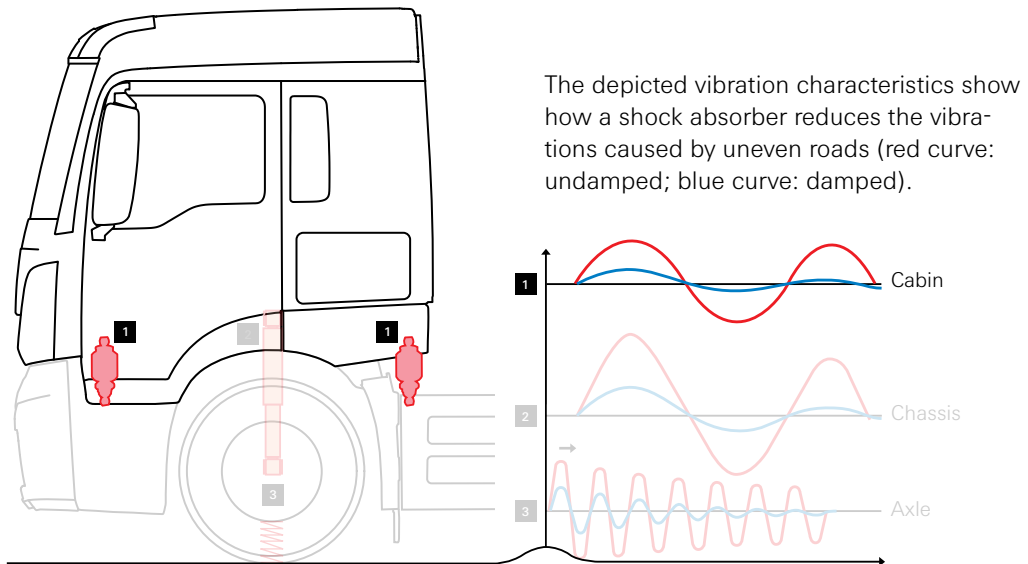

ZF cab dampers provide greater safety, comfort, and stability. Improved comfort levels reduce driver fatigue, increasing performance and thereby driving safety.

Ride comfort in commercial vehicles is considerably enhanced by cabin suspension and cabin damping that is separate from the chassis.

Vehicle cabs differ in size, equipment, and weight depending on their application. Each different cabin design requires an individual spring/damper solution.

ZF offers a range of products from lateral dampers (nearly horizontal installation position), steel spring, and air spring modules to CALM® Cabin Air Leveling Modules and CDC® controlled damping.

Productrange cabin damping



Steel spring module



Air spring module



CALM® – Cabin
Air Leveling Module



CDC® – Continuous
Damping Control

Steel spring module

The steel spring is mounted concentrically on the damper. It is designed in various spring characteristics depending on the use case. The cabin level is independent of the system and is not controlled. It depends on the load. Different cabin weights require the steel spring suspension to have different load carrying capacities to maintain ride height levels. This can be achieved by different spring rates, different preload, or a mechanical height

adjustment known as spring mount adjustment.

Application

The steel spring module is used with all types of commercial vehicles with limited load differences. This includes primarily construction and delivery vehicles as well as tractors and special vehicles – precisely where robustness takes center stage.

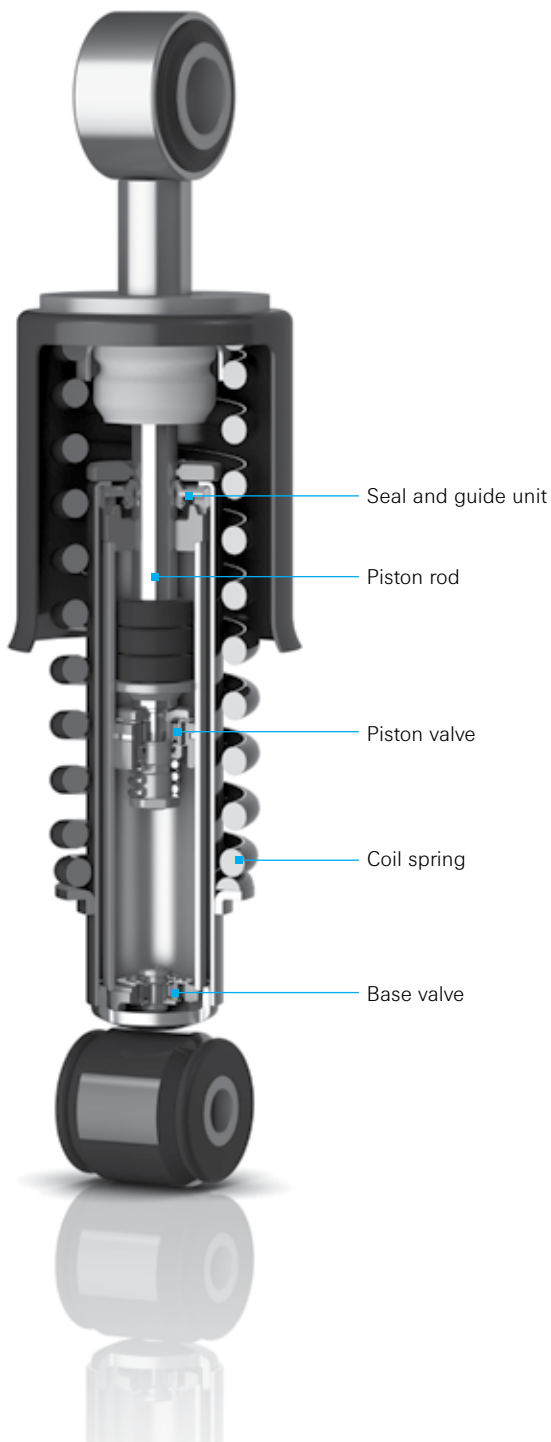

Spring mount adjustment



The same spring damper modules can be used for different cabin weights by adjusting the spring mount.



Horizontal dampers reduce the infamous „cabin shake“ syndrome and thus increase safety and comfort.



Advantages

- Independent from other systems, such as air supply
- Outstanding cost/benefit ratio
- Small installation space required
- The robust design enables rough-terrain applications, e.g. for construction vehicles

Air spring module

Pneumatic suspension allows for ride height control. It compensates load differences resulting from different cabin weights/equipment and cabin movements while the vehicle is operated. As good ride comfort is based on low natural frequency, cabin suspensions – especially in medium and heavy-duty vehicles – are equipped with pneumatic suspension.

Loads between 2,000 N and 4,000 N can be supported with an internal pressure of 5 bar in the air spring bellow.

A special air spring piston shape for the air spring yields low spring rates in mid stroke, but a very strong progression towards the end stops. Thus the driver cab remains stable at a high level of ride comfort.

Application

The air spring module is used for driver cabs with high comfort requirements and for trucks, tractors, construction vehicles, and special vehicles.

Steel spring module and Air spring module in Comparison

Requirements	Steel spring	Air spring
Hydraulic damper or suspension strut with concentrically aligned spring element.	☐	☐
Typical natural frequency of the driver's cabin	1.8 - 3.0 Hz	1.0 - 1.4 Hz
Low natural frequency at design height and progressive spring forces at the stroke end stops	To a limited extent	☐
Dampers with VARIO design with stroke-dependent characteristics possible	☐	☐



Advantages

- Ride height control with different cabin equipment/loading
- Constant, comfortable characteristic frequency
- Increased ride comfort
- Small installation space required

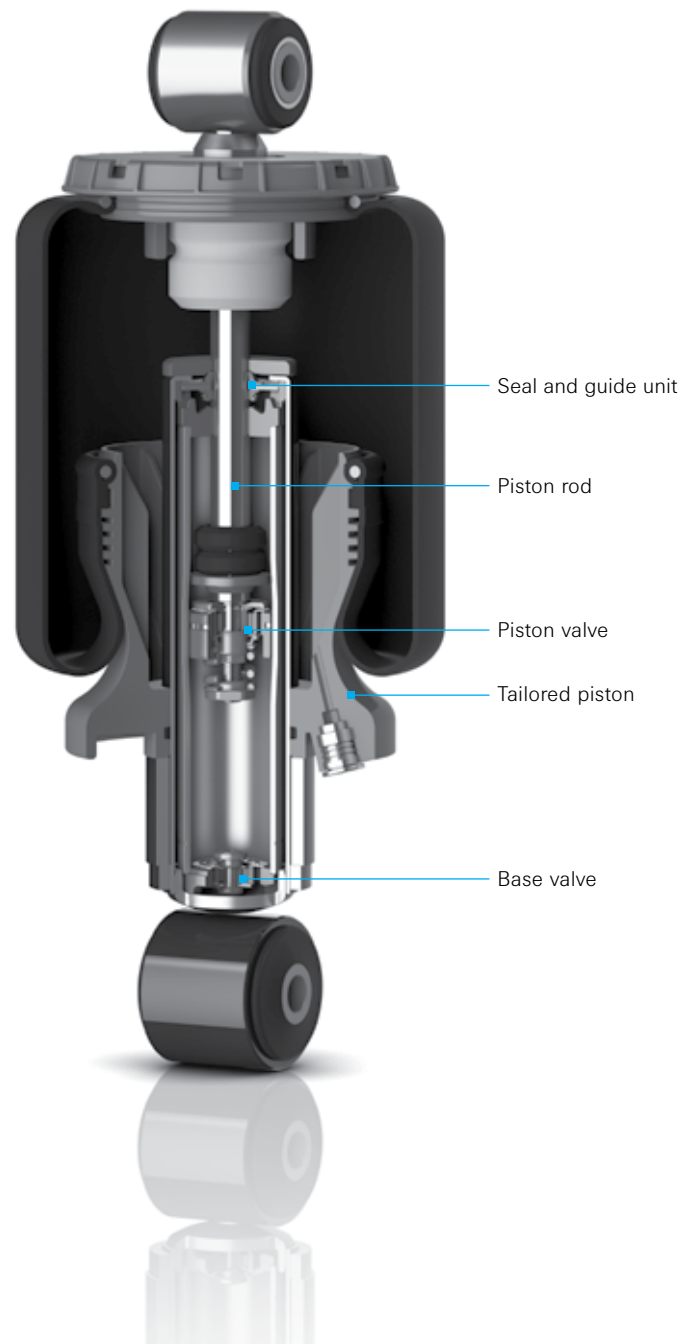

CALM[®] – Cabin Air Leveling Module

With CALM[®] (Cabin Air Leveling Module), ZF has developed a unique air spring damper module. This module contains the leveling system for the driver’s cabin. CALM[®] appears very similar to conventional air spring modules. Height leveling is no longer controlled via an external valve but is directly implemented in CALM[®].

The module also replaces a number of additional external components. Depending on the ride height, the valve regulates the pressure in the air springs and provides a constant ride height of the driver’s cabin. CALM[®] has proven its worth under the toughest conditions – also in construction vehicles and tractors. Thus, the driver can rely on the advantages of an air suspended cab even with demanding applications.

Application

CALM[®] is used in all types of air spring cabins that require high comfort levels and are subject to a wide range of different load conditions. Areas of application include trucks, agricultural tractors, construction vehicles, and special vehicles.

CALM[®]-Solution

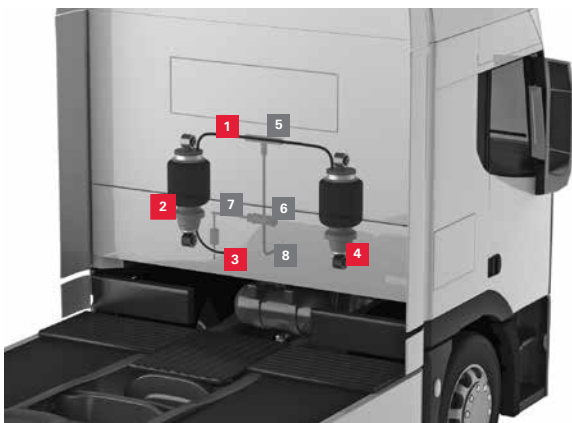

- 1 Air line
- 2 CALM[®]
- 3 Air supply line
- 4 Conventional air spring module
- 5 Air distributor
- 6 External level control valve
- 7 Linkage and adjusting mechanism
- 8 Air supply line

x External components for height leveling have largely been eliminated.



Advantages

- Damping and air suspension with integrated height leveling
- Low susceptibility of the height leveling to external influences such as dirt and damage
- Modular design
- Smaller installation space required
- No adjusting during assembly
- Fewer individual components

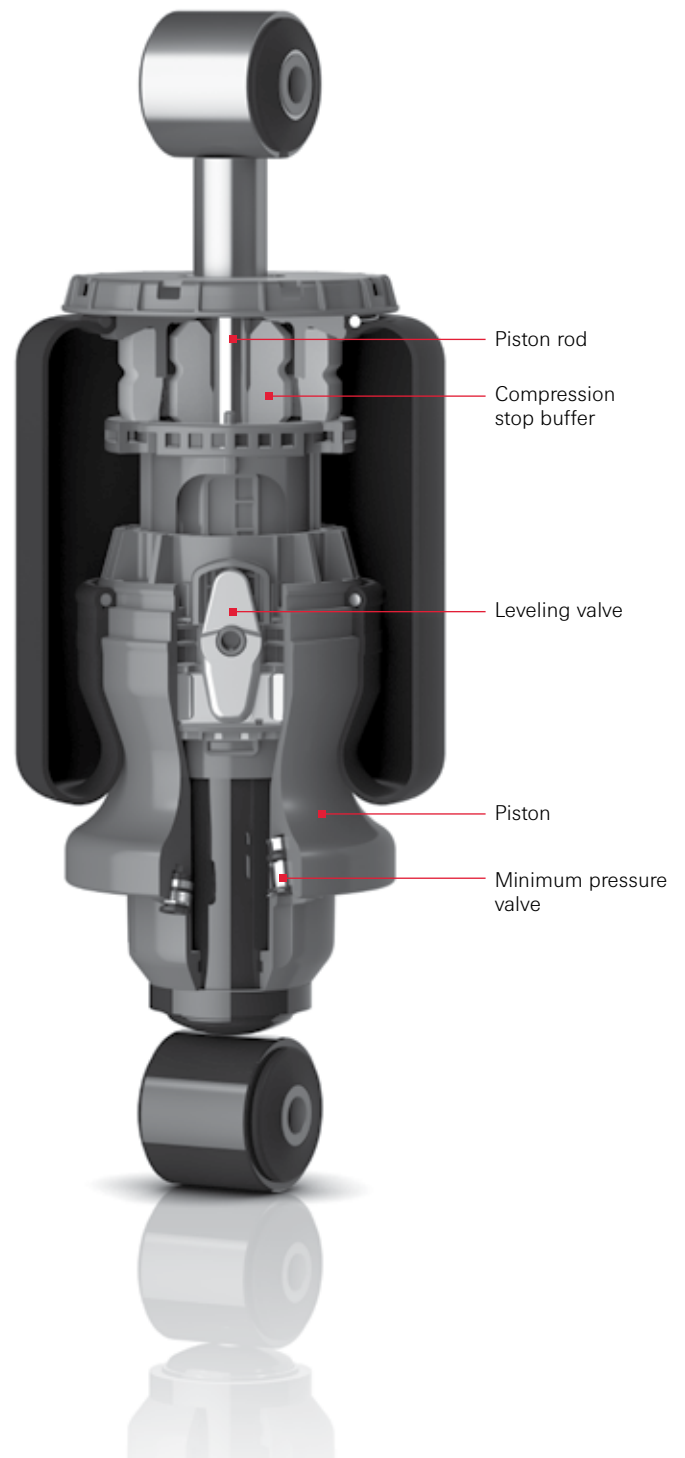

CDC® – for the cabin

CDC® eliminates the trade-off between comfort and stability in the cabin. It solves the conflicting demands for higher suspension and damping comfort on the one hand, and for good cabin stability while accelerating, braking and cornering on the other.

The damping forces are adjusted to the optimum level within milliseconds on the basis of data provided by the vehicle’s sensors. At straight-ahead driving on average quality roads, the electronics reduces damping forces.

As a result, cabin suspension is soft and comfortable. As soon as excitation of the cabin changes due to lane changes, braking maneuvers, or gear shifts, CDC® keeps the cabin stable by increasing damping forces.

The system also contributes to fuel efficiency by enabling shorter gear-shifting times and reducing tractive force interruption without compromising ride comfort, e.g. due to stronger cabin pitch.



CDC®-Control loop (Example)

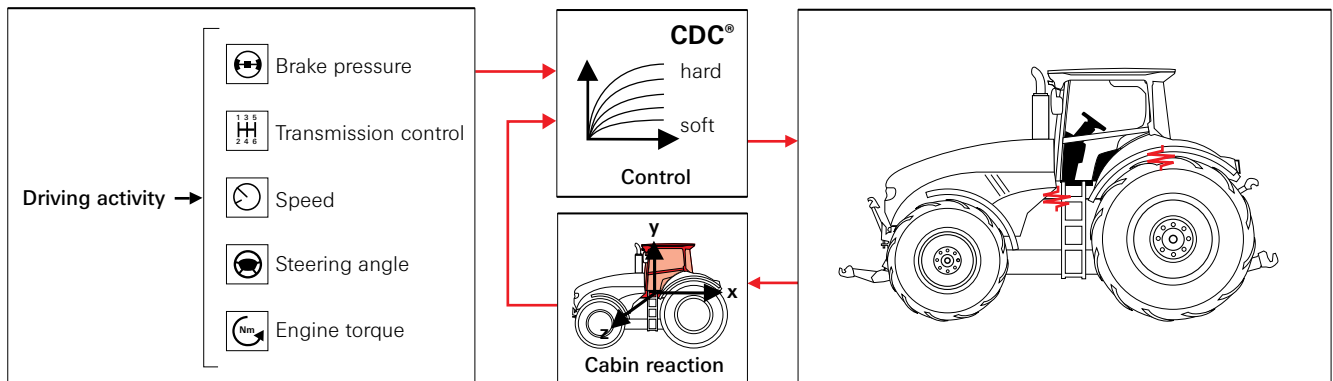

Intelligent lightweight design

In developing new components and systems, ZF always strives for efficiency and resource conservation. This applies equally to products in the areas of axle and cabin suspension.

Good reasons to lose weight

The basic conditions are clear: Commercial vehicles must lose weight in the future. Customers benefit from reduced curb weight with increased payloads. Weight reduction also helps to achieve the demanding targets for reduced fuel consumption. In addition, reducing the weight of unsprung masses (axles, wheels, brakes, shock absorbers, etc.) creates additional potential for improving comfort.

Lightweight design for axle dampers

ZF lightweight axle dampers combine various materials and technologies from the existing ZF technology portfolio. Hollow piston rods, aluminum containers – with reduced wall thicknesses in some case – and a redesigned plastic protective tube are used in the lightweight versions of dampers sizes N36 and N45.

The weight reduction in comparison to a corresponding volume production shock absorber of size N36 is about 40% or 1.5kg.

Lightweight design for cabin damper modules

Not only are alternative materials such as aluminum and fiber composites being used in cabin damper modules; there is also a further integration of functions, for instance into the outer tube of the damper. This reduces complexity during assembly and allows for resource conservation during manufacturing.

As with axle dampers, corrosion characteristics are also being significantly improved with cabin applications.



The intelligent combination of innovative materials and procedures allows for weight reductions of up to 40%.



Advantages

- Resource conservation in production
- Fuel savings
- Increase in payload
- Greater comfort potential by reducing the unsprung masses
- Improvement in corrosion resistance
- Use of innovative materials and procedures from the ZF technology portfolio

ZF Friedrichshafen AG

Commercial Vehicle Technology

CV Chassis Technology

Dr.-Jürgen-Ulderup-Straße 7

32351 Stemwede

Germany

Phone +49 5474 60-0

Fax +49 5474 60-902000

www.zf.com